

THIS DRAWING IS UNPUBLISHED. RELEASED FOR PUBLICATION  
 © COPYRIGHT BY TYCO ELECTRONICS CORPORATION. ALL RIGHTS RESERVED.

LOC		DIST		REVISIONS			
P	LTR	DESCRIPTION		DATE	DWN	APVD	
GP	00	0		RELEASED PER EC 0S13-0207-05	29JUN05	SW	JG

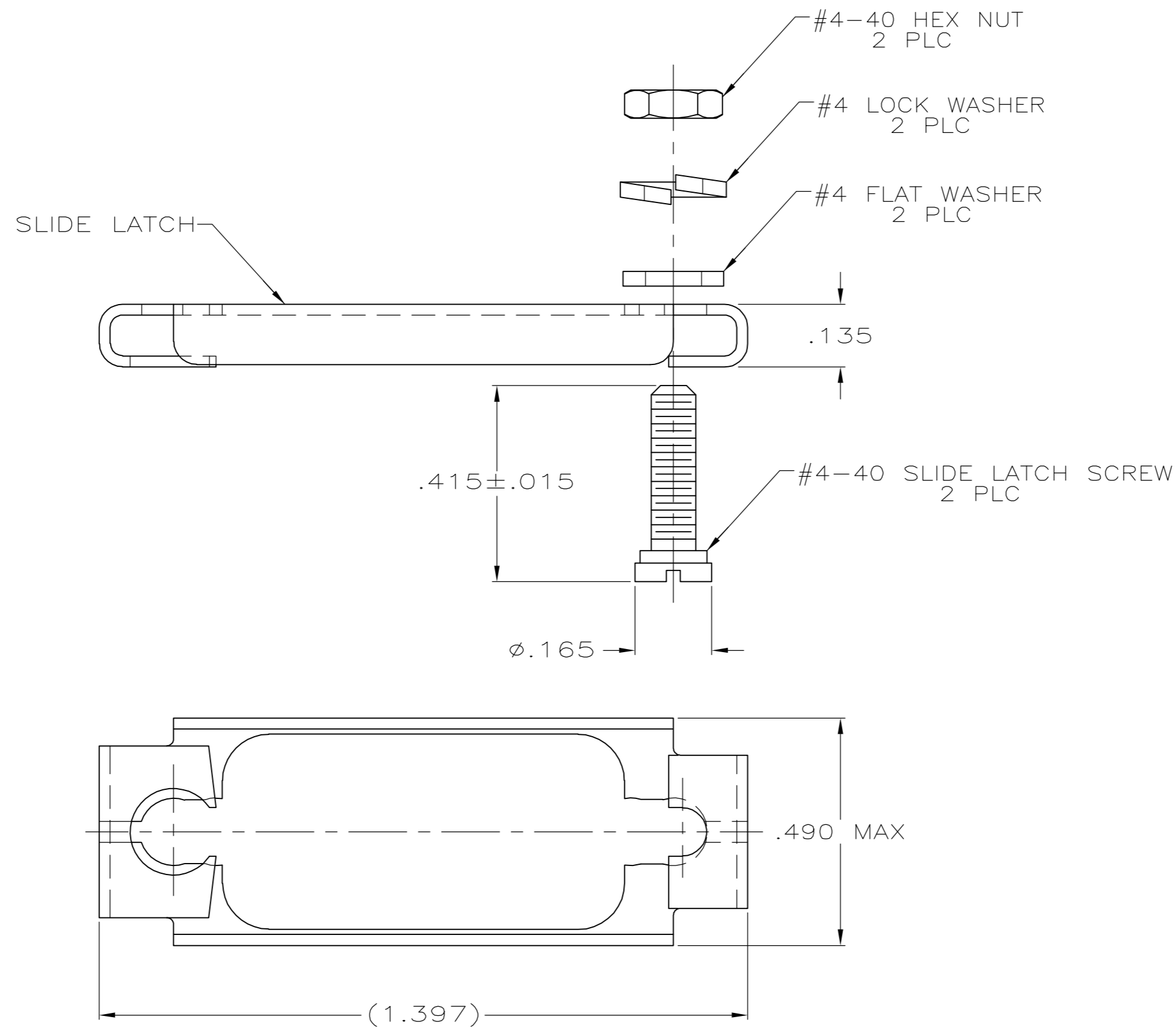

1. PARTS PACKAGED UNASSEMBLED.
2. PARTS PACKAGED AS A UNIT KIT.
3. THIS KIT CAN BE USED WITH CABLE CLAMP BODIES THAT DO NOT EXTEND BEYOND THE FRONT FLANGE OF THE CONNECTOR OR ON CONNECTORS WITHOUT CABLE CLAMPS.
4. ZINC PLATED .000200-.000400 THICK, YELLOW CHROMATE COATING.

THIS DRAWING IS A CONTROLLED DOCUMENT.		DWN	29JUN05	Tyco Electronics Corporation Harrisburg, Pa 17105-3608																	
DIMENSIONS: INCHES		CHK	29JUN05																		
TOLERANCES UNLESS OTHERWISE SPECIFIED:		APVD	29JUN05																		
<table border="1"> <tr><td>0 PLC</td><td>±</td><td>-</td></tr> <tr><td>1 PLC</td><td>±</td><td>-</td></tr> <tr><td>2 PLC</td><td>±</td><td>-</td></tr> <tr><td>3 PLC</td><td>±</td><td>.005</td></tr> <tr><td>4 PLC</td><td>±</td><td>-</td></tr> <tr><td>ANGLES</td><td>±</td><td>-</td></tr> </table>		0 PLC	±			-	1 PLC	±	-	2 PLC	±	-	3 PLC	±	.005	4 PLC	±	-	ANGLES	±	-
0 PLC	±	-																			
1 PLC	±	-																			
2 PLC	±	-																			
3 PLC	±	.005																			
4 PLC	±	-																			
ANGLES	±	-																			
MATERIAL		PRODUCT SPEC		KIT, SLIDE LATCH, SIZE 1, 9 POSITION, AMPLIMITE																	
SLIDE LATCH: STAINLESS STEEL		APPLICATION SPEC		SIZE	CAGE CODE																
HARDWARE: STEEL PER ASTM A108		FINISH		DRAWING NO	RESTRICTED TO																
HARDWARE: 4		WEIGHT		A2	00779																
		CUSTOMER DRAWING		C=5745404																	
		SCALE		SHEET																	
		4:1		1 OF 1																	
				REV 0																	

5745404-1  
PART NO

5745404